

# FORWARD RELAYS



29×12.7×15.8

# NT75

UL E158859

40020063 CQC 10002042304

## Features

- Small size, light weight. Low coil consumption.
- Switching capacity up to 20A.
- PC board mounting.
- Suitable for household electrical appliances, automation system, electrical equipment, instrument, meter telecommunication facilities and remote control facilities.
- Product in accordance to IEC60335-1 available.

## Ordering Information

**NT75 1C S 0.41 3.5 N G 12 DC12V W**  
 1 2 3 4 5 6 7 8 9 10

1 Part number: T75	7 Contact plating: Nil:Standard; G: Au plated
2 Contact arrangement: 1A:1A; A2:1A2; 1C:1C; C2:1C2; 2A:2A; 2C:2C	8 Contact rating: 1A,1C:12A,16A/250VAC 30VDC 2A,2C(0.41W):NO:8A/277VAC,30VDC NC:8A/277VAC,30VDC
3 Enclosure: S: Wash tight; Z: Flux proof	2A(0.53W):10A/250VAC,30VDC
4 Coil power: 0.25:0.25W; 0.41:0.41W; 0.53:0.53W (2A:10A/250VAC,30VDC)	9 Coil rated voltage(V): DC:5,6,9,12,24,48
5 Pole-distance: 3.5:3.5mm; 5.0:5.0mm	10 W: 335 compliant; Nil:Standard
6 Contact material: NIL:AgSnO <sub>2</sub> ; N:AgNi	

## Contact Data

Contact Arrangement	1A、1A2(SPSTNO) 1C、1C2(SPDT(B-M)) 2A(DPSTNO) 2C(DPDT(B-M))	
Contact Material	AgSnO <sub>2</sub> AgNi	
Contact Rating (Resistive)	1A,1C:12A,16A/250VAC,30VDC (Rushing current 80A) 2A,2C(0.41W):NO:8A/277VAC,30VDC; NC:8A/277VAC,30VDC 2A(0.53W):10A/250VAC,30VDC	
Max. Switching Power	480W 4000VA 2C:300W 2500VA	
Max. Switching Voltage	125VDC 440VAC	Max. Switching Current:20A
Contact Resistance	≤100mΩ	Item 4.12 of IEC 61810-7
Operational Life	Electrical	1×10 <sup>5</sup> 5×10 <sup>4</sup> (10A/250VAC 85°C) 1×10 <sup>4</sup> (10A/30VDC 85°C) Item 4.30 of IEC 61810-7
	Mechanical	1×10 <sup>7</sup> Item 4.31 of IEC 61810-7

**CAUTION:** 1.For the intermediate current(10mA/6VDC~100mA/28VDC), it only applies to the room temperature.  
 2.For gold plated version, the min. Switching current and min. Switching voltage is 50mA/6VDC; for non gold plated version (standard type),the min. switching current and min. switching voltage is 100mA/6VDC.

## Coil Parameter

Dash numbers	Coil voltage VDC		Coil resistance Ω ±10%	Pick-up voltage VDC(max) (70%of rated voltage )	Drop-out voltage VDC(min) (10% of rated voltage)	Coil power W	Operate time ms	Release time ms
	Rated	Max.						
005-250	5	6.5	100	3.5	0.5	0.25	≤10	≤5
006-250	6	7.8	144	4.2	0.6			
009-250	9	11.7	324	6.3	0.9			
012-250	12	15.6	576	8.4	1.2			
024-250	24	31.2	2304	16.8	2.4			
048-250	48	62.4	9216	33.6	4.8			
005-410	5	6.5	61	3.5	0.5	0.41	≤10	≤5
006-410	6	7.8	88	4.2	0.6			
009-410	9	11.7	198	6.3	0.9			
012-410	12	15.6	351	8.4	1.2			
024-410	24	31.2	1405	16.8	2.4			
048-410	48	62.4	5620	33.6	4.8			

## Coil Parameter

Dash numbers	Coil voltage VDC		Coil resistance $\Omega \pm 10\%$	Pick-up voltage VDC(max) (70% of rated voltage)	Drop-out voltage VDC(min) (10% of rated voltage)	Coil power W	Operate time ms	Release time ms
	Rated	Max.						
005-530	5	6.5	47.1	3.5	0.5	0.53	$\leq 15$	$\leq 8$
006-530	6	7.8	67.9	4.2	0.6			
009-530	9	11.7	152.8	6.3	0.9			
012-530	12	15.6	271.7	8.4	1.2			
024-530	24	31.2	1086.8	16.8	2.4			
048-530	48	62.4	4347.2	33.6	4.8			

**CAUTION:** 1. The use of any coil voltage less than the rated coil voltage will compromise the operation of the relay.  
2. Pickup and release voltage are for test purposes only and are not to be used as design criteria.

## Characteristics

Insulation Resistance	1000M $\Omega$ min (at 500VDC)	Item 4.11 of IEC 61810-7
Dielectric Strength Between Contacts Between Contact and Coil	50Hz 1000V 50Hz 5000V	Item 4.9 of IEC 61810-7 Item 4.9 of IEC 61810-7
Shock Resistance	98m/s <sup>2</sup> 11ms	Item 4.26 of IEC 61810-7
Vibration Resistance	10Hz~55Hz Double amplitude 1.5mm	Item 4.28 of IEC 61810-7
Terminals Strength	10N	Item 4.24 of IEC 61810-7
Ambient Temperature	-40 $^{\circ}$ C~85 $^{\circ}$ C	
Relative Humidity	5% to 85%	Item 4.16 of IEC 61810-7
Mass	12.5g 13.2g	Item 4.7 of IEC 61810-7

## Safety Approvals

Safety approval	UL&CUR	VDE	CQC
Load	1A, 1C: 12A, 16A/250VAC; 12A/30VDC(1C) 2A, 2C: 8A/277VAC, 30VDC 2A(0.53W): 10A/250VAC, 30VDC	1A, 1C: 16A/250VAC 2A, 2C: 8A/250VAC	1A, 1C: 16A/250VAC 2A, 2C: 8A/250VAC

## Dimensions

mm

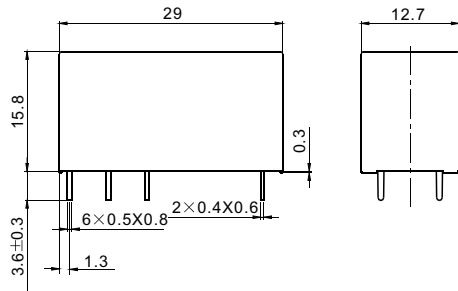

Dimension

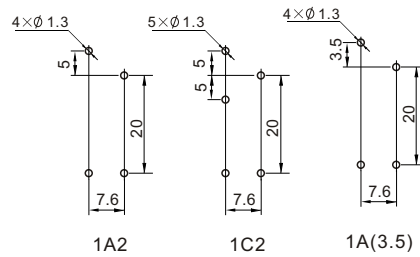

1A2 1C2 1A(3.5)

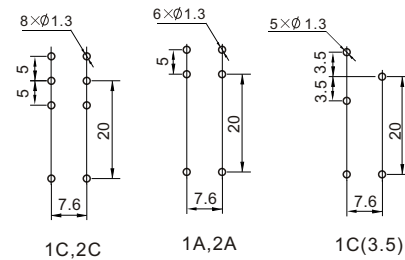

1C,2C 1A,2A 1C(3.5)

Mounting (Bottom view)

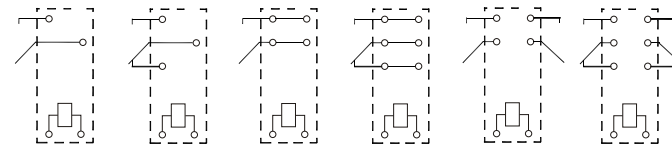

1A(3.5),1A2 1C(3.5),1C2 1A 1C 2A 2C

Wiring diagram(Bottom view)

**CAUTION:** In case of no tolerance shown in outline dimension: outline dimension  $\leq 1\text{mm}$ , tolerance should be  $\pm 0.2\text{mm}$ ; outline dimension  $> 1\text{mm}$  and  $\leq 5\text{mm}$ , tolerance should be  $\pm 0.3\text{mm}$ ; outline dimension  $> 5\text{mm}$ , tolerance should be  $\pm 0.4\text{mm}$ .

## Reference Data

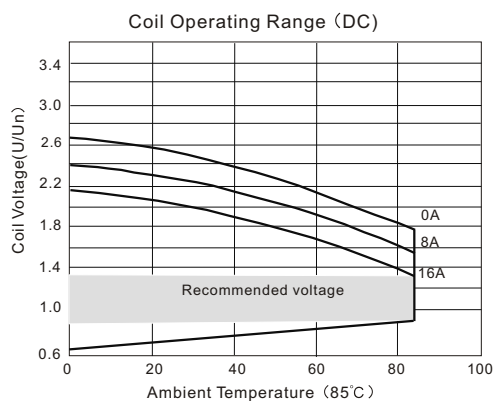
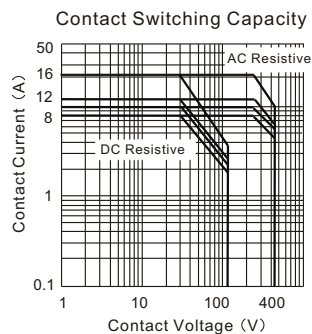

Notes: The use of a relay with an energising voltage other than the rated coil voltage may lead to reduced electrical life. An energising voltage over the above range may damage the insulation of relay coil.